

Belt Drive Tubeaxial Fan

DIMENSIONS for Steel Construction

| FAN SIZE | A | B | C | D | E | | F | G | |
|----------|---------------------------------|---------------------------------|--------------------------------|---|------------------------------|-----------------------------|----|-----|-----------------------------|
| | | | | | std | max | | std | max |
| 24 | 25 ¹ / ₁₆ | 29 ³ / ₁₆ | 27 ³ / ₈ | 2 | ³ / ₁₆ | ¹ / ₄ | 30 | 14 | ¹ / ₄ |
| 30 | 31 ¹ / ₁₆ | 35 ³ / ₁₆ | 33 ³ / ₈ | 2 | ³ / ₁₆ | ¹ / ₄ | 33 | 14 | ¹ / ₄ |
| 36 | 37 ¹ / ₁₆ | 41 ³ / ₁₆ | 39 ³ / ₈ | 2 | ³ / ₁₆ | ¹ / ₄ | 36 | 14 | ¹ / ₄ |
| 42 | 43 ¹ / ₁₆ | 47 ³ / ₁₆ | 45 ³ / ₈ | 2 | ³ / ₁₆ | ¹ / ₄ | 39 | 14 | ¹ / ₄ |
| 48 | 49 ¹ / ₁₆ | 53 ³ / ₁₆ | 51 ³ / ₈ | 2 | ³ / ₁₆ | ¹ / ₄ | 42 | 14 | ¹ / ₄ |
| 54 | 55 | 59 ³ / ₁₆ | 57 ³ / ₈ | 2 | ³ / ₁₆ | ¹ / ₄ | 45 | 12 | ¹ / ₄ |
| 60 | 60 ¹ / ₁₆ | 65 ³ / ₁₆ | 63 ³ / ₈ | 2 | ³ / ₁₆ | ¹ / ₄ | 48 | 10 | ¹ / ₄ |

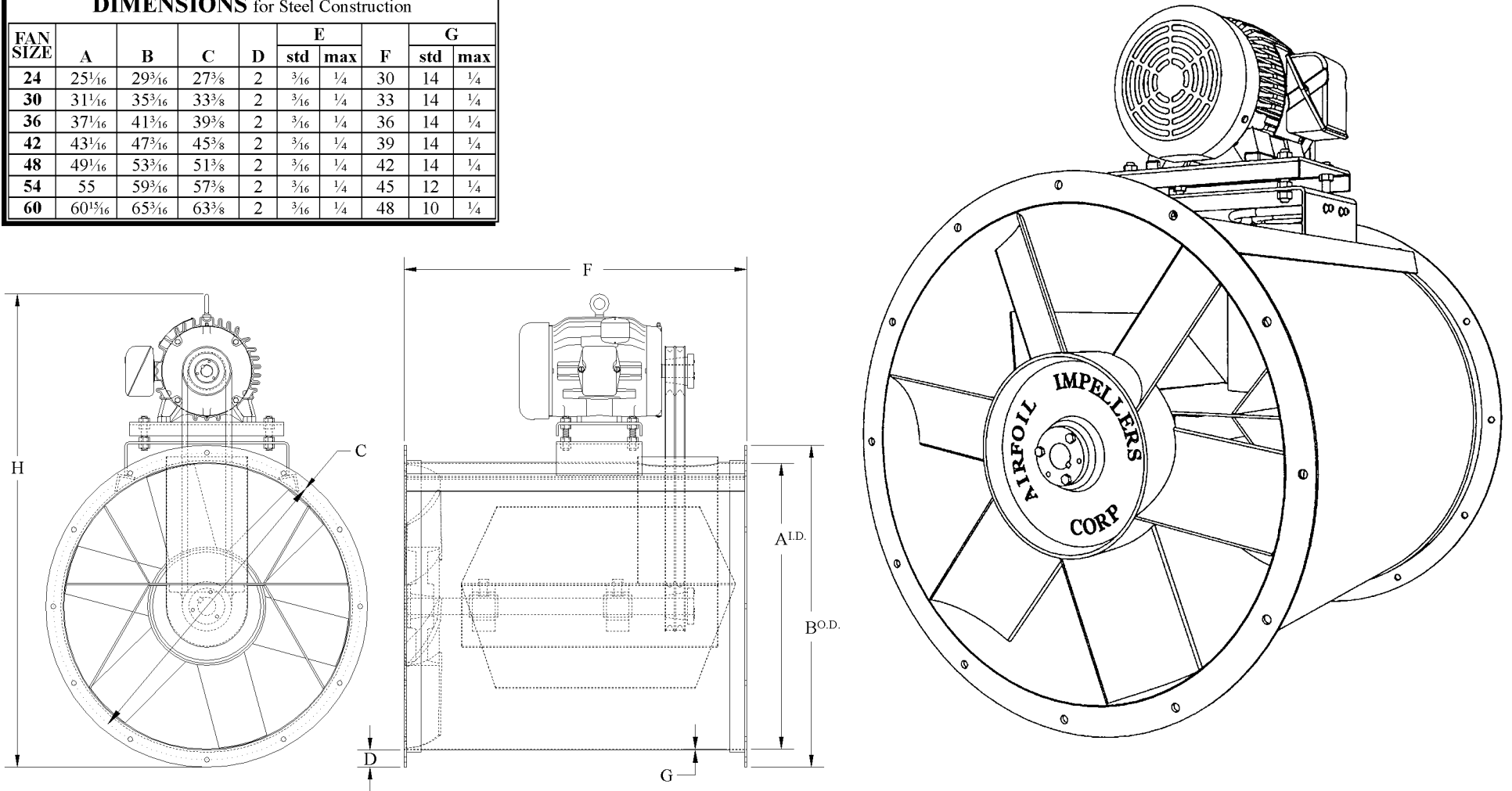

AIRFOIL IMPELLERS

P.O.Box 9966
College Station, TX 77842
PHONE: (979) 822-6418
FAX: (979) 775-5588

TITLE: Belt Drive Tubeaxial Fan

NOTE: Dimensions shown are subject to change. Please contact factory if a certified drawing is needed.

*H is dependent on motor frame.

©2003 Airfoil Impellers Corp.

web: <http://www.airfoil.com>

email: sales@airfoil.com

